

FORD Radial Mount HP Efficient Alternators

Fits FORD Chassis

- **Efficient**
- **High Output**

12V-240A

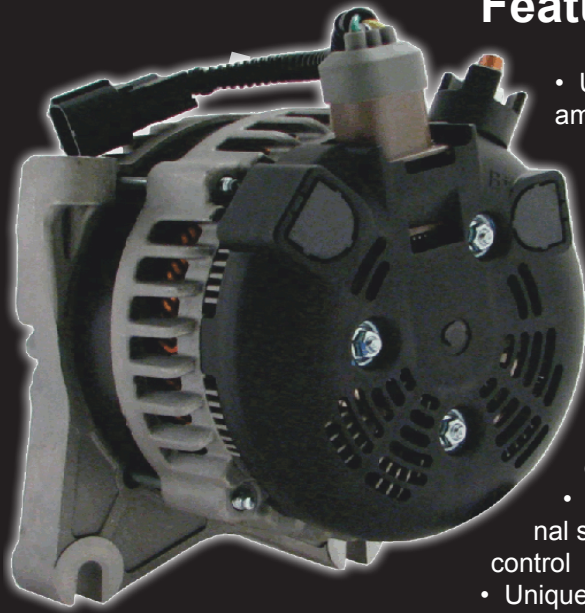

Features:

- Unmatched charging curve at idle - exceeding 170 amps
- Hair Pin, 6 phase stator maximizes slot fill
- OEM engineered to produce high output - this is not a "Pumped Up" auto unit
- 12 press fit 70A diodes with welded leads
- Unmatched heat recovery
- Super high heat bearings with 200+ degree seals and synthetic grease
- 96 slot stator compared to 36 slot provides superior efficiency
- Shaft design accepts passive, IDP, and OWC pulley designs
- Universal Regulator circuit adapts to internal or external sensing as well as PCM or ignition excitation with lamp control
- Unique rectifier design allows for 3 different output post positions

Typical HP Series Output Curve

RPM	1000	2000	3000	4000	5000
AMPS	6	173	217	235	242

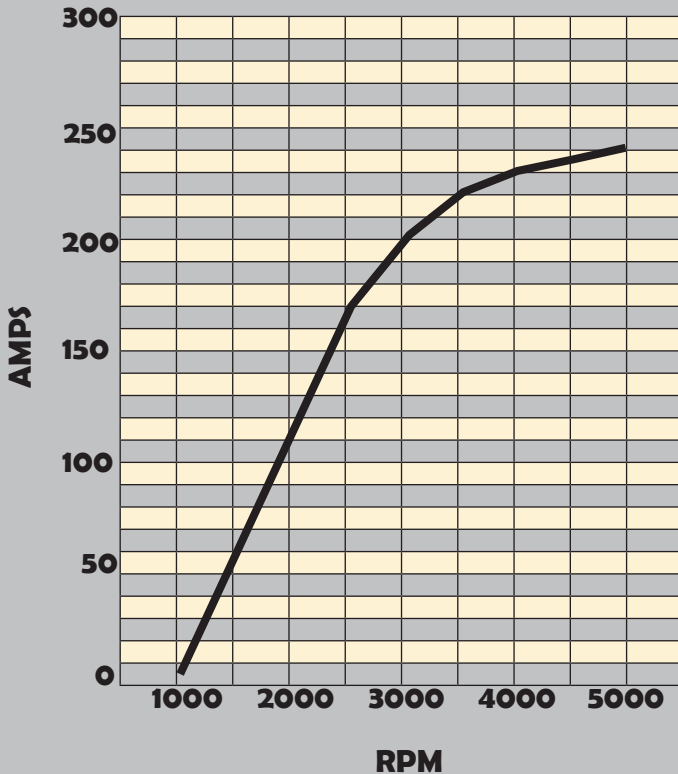

See the Difference?

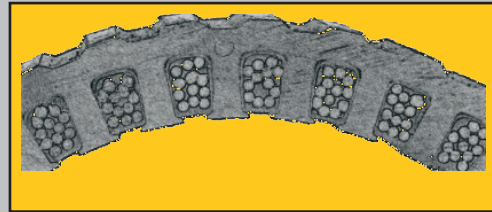

Round Wire Stator with Air Gaps Limiting the Slot Fill

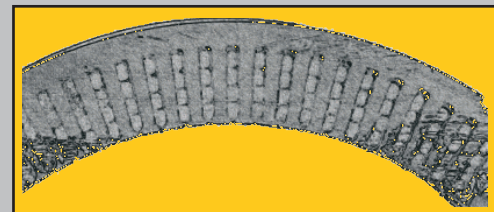

Hair Pin Stator with Solid Copper Maximized the Slot Fill and Copper to Steel Coupling

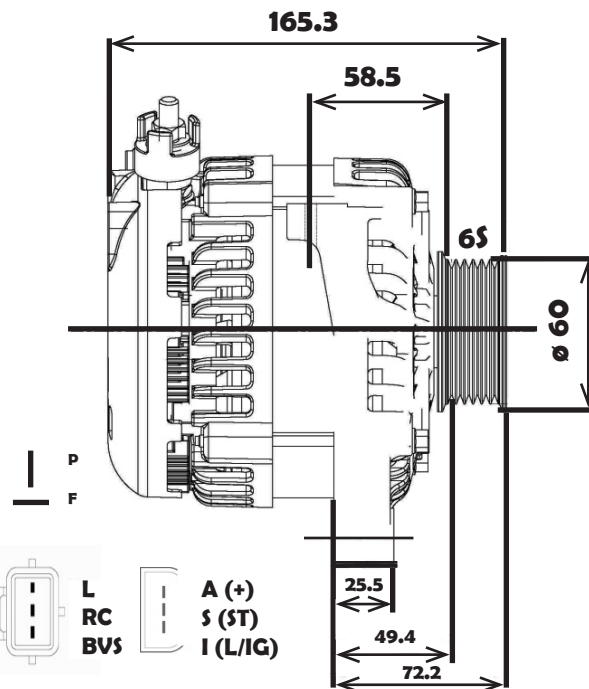
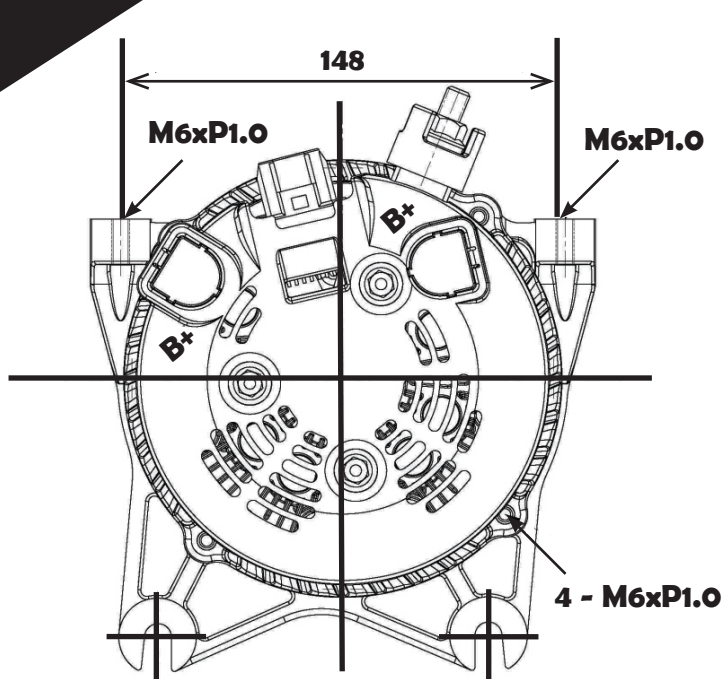

AVAILABLE OPTIONS

11434N

6G CLUTCH STYLE PULLEY, SQ PLUG

REPLACES: Replaces: 104210-6181, 9C2AZ-10346-C

KARAM #: 8516, 8444, 8315, 11026

FITS: 2009 FORD E-Series van 4.6L, 5.4L, 6.8L Engines

7795ND-240A

6G SERPENTINE PULLEY, SQ PLUG

REPLACES: F8AU-10300-AB, AC, AD, F8AZ-10346-AB

A160201, 210-0646

KARAM #: 7795, 8252, 8310

FITS: 1998-2002 FORD CROWN VICTORIA, LINCOLN TOWN CAR, MERCURY MARQUIS 4.6L Engine

NOTE: With 50-13239 2S Conversion Harness

PX2RND-240A

6G SERPENTINE PULLEY, EXTERNAL REGULATOR

REPLACES: PENNTEX PX-2R-5, PX-2RD-200, 24-203, 24-203

FITS: 1997-1999 FORD GAS Engines

NOTE: Externally Regulated

7764ND-240A

6G SERPENTINE PULLEY, D PLUG

REPLACES: F6AZ-10346-AA, F3AU-10300-AC, BA, F3AZ-10346-A

5C2Z-10346-BA, F6PU-10346-AA, F85U-10300-BA, AL7537HO

KARAM #: 7753, 7764, 7776, 7790, 7791, 8267

FITS: 1992-2008 FORD, LINCOLN, MERCURY 4.6L - 6.8L Engines

NOTE: 8G Optional Pulley 7990-9096

8303ND-240A

6G CLUTCH STYLE PULLEY, SQ PLUG

REPLACES: 3L74-10300-AA, BA, BB, 3L74-10346-AA,

3L74Z-10346-AA, BA, AL160202

KARAM #: 8303, 8307, 7796,

7798, 8306, 8316, 8478, 8479, 7799, 8317, 7797

FITS: 2003-2004 FORD EXPEDITION 4.6L, 5.4L Engines
 LINCOLN NAVIGATOR 4.6L Engine

PX5RND-240A

6G SERPENTINE PULLEY, EXTERNAL REGULATOR

REPLACES: PENNTEX PX-5RD-230, PX-5R-200

FITS: 1997-2007 FORD GAS 6.8L V10 Engines

NOTE: Externally Regulated, Dual Positive Battery Posts